

# 8000 Series Liquid Flow Meter

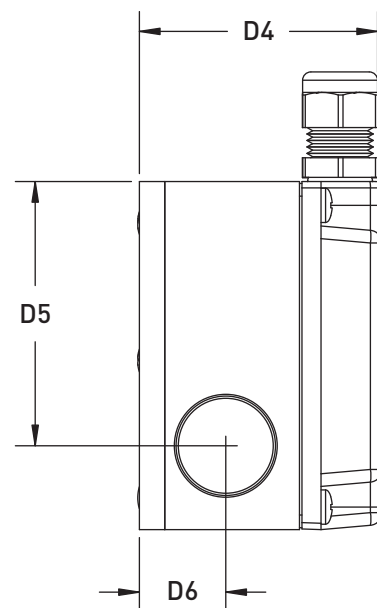

MODEL	D1	D2	D3	D4	D5	D6
08004BN013 08004PN2	3.00 in	2.74 in	3.60 in	1.82 in	2.08 in	0.61 in
08004BN03 08004PN4	76.20 mm	69.60 mm	91.44 mm	46.23 mm	52.83 mm	15.49 mm
08004BN06 08004SN013						
08004BN1 08004SN03						
08004BN2 08004SN06						
08004BN4 08004SN1						
08004PN013 08004SN2						
08004PN06 08004SN4						
08004PN1						
08006BN9 08006SA4						
08006PN10 08006SN9						
08006SA2						
08008BN14 08008SA10	3.00 in	2.74 in	3.60 in	1.91 in	2.08 in	0.68 in
08008PN14 08008SN14	76.20 mm	69.60 mm	91.44 mm	48.51 mm	52.83 mm	17.27 mm
08012BN16 08012SA16	3.00 in	2.74 in	3.60 in	2.20 in	2.08 in	0.80 in
08012BN40 08012SN16	76.20 mm	69.60 mm	91.44 mm	55.88 mm	52.83 mm	20.32 mm
08012PN19 08012SN40						
08016BN40 08016SA40	3.60 in	3.16 in	4.02 in	2.69 in	2.26 in	0.98 in
08016BN60 08016SN40	91.44 mm	80.26 mm	102.11 mm	68.33 mm	57.40 mm	24.89 mm
08016PN50 08016SN60						

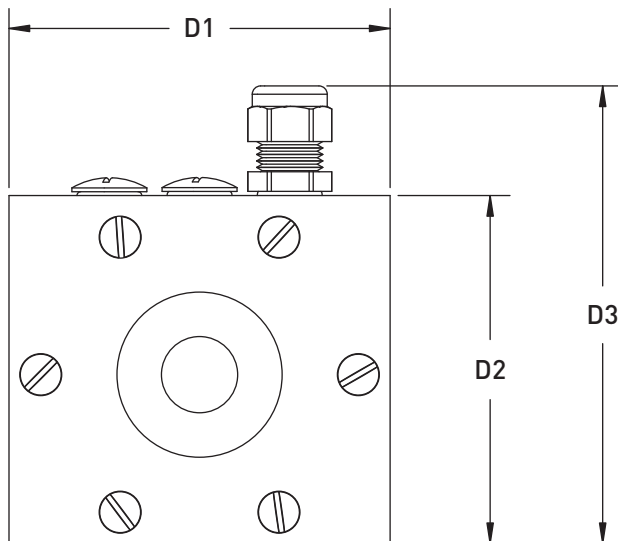
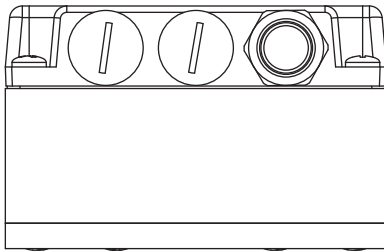
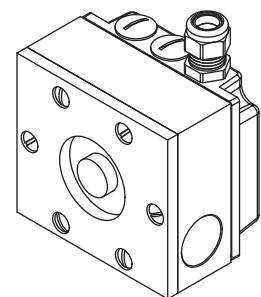

FOR REFERENCE ONLY

INFORMATION IN THIS DOCUMENT WAS CORRECT AT THE TIME OF PRINTING; HOWEVER, SPECIFICATIONS ARE SUBJECT TO CHANGE AS PROTEUS INDUSTRIES' CONTINUOUS IMPROVEMENT PROCESSES ESTABLISH NEW CAPABILITIES.  
© PROTEUS INDUSTRIES INC. ALL RIGHTS RESERVED.