

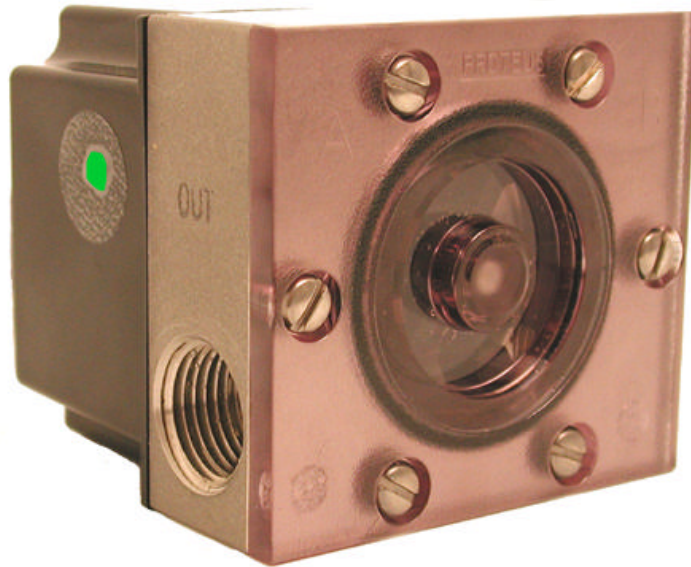

Proteus Industries Inc.



200 Series Flow Meters

Technical Reference Manual

Can we Improve? Tell our President!

Can we improve our product, our support or this manual?

We are committed to continuous improvement and welcome your help. Fax, mail or e-mail your ideas to me, Jon Heiner.

If you include your phone number, I will give you a personal reply. Or if you prefer, call me on my direct line.

Phone: (650) 943-4102

Fax: (650) 965-9355

E-mail: Jon@proteusind.com

Proteus 5-Year Warranty

A full statement of our Warranty is available at our website, www.Proteusind.com.

Contents

	Page
Section 1: Overview	3
Section 2: Flow Ranges and Pipe Connections	3
Section 3: How do they work?	4
Section 4: Physical Installation	4
Pipe or tubing mounting	
Panel mounting	
Plumbing Connections	
Filtering	
Fluid Temperature Range	
Section 5: Electrical Connections	7
Relay output versions	
Transistor output versions	
Section 6: Setting the Trip Point	8
Relay output versions	
Transistor output versions	
Section 7: Maintenance	9
Section 8: Calibration	11
Section 9: General Trademarks	12
Section 10: Reference Documents	12
Circuit Diagrams	
Current Data Sheet for 200 Series Flow Meter is available at www.proteusind.com	

Section 1: Overview

Metering flow switches such as the Proteus 500 and 800 Series with Hall Effect sensors may be better suited for interfacing with current electronic control systems. Please contact us for assistance in selecting a sensor best suited to your application!

Proteus 200 Series Flow Meters are designed to monitor the flow of fluid through a line. They are frequently used to assure that water is flowing in a cooling circuit, however they may be used in a wide variety of applications with many different fluids.

Section 2: Flow Ranges and Pipe Connections

Table 1 lists the model numbers and flow ranges. Model 200XX versions can be configured in one of three different ranges, depending on the placement of the supplied blanking plugs.

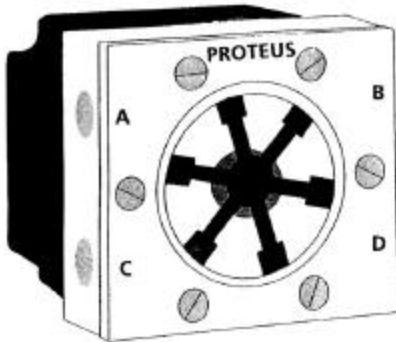

- To operate across the A to B flow path, blanking plugs must be placed in ports C and D.
- To operate across the B to C flow path, blanking plugs must be placed in ports A and D.

See Note below Table 1

- To operate across the D to C flow path, blanking plugs must be placed in ports A and B.

Model Number XX = 12 or 24	Connection Size	Flow Range		Inlet Port	Outlet Port
		GPM	LPM		
200XX	1/4" FNPT	Selectable		Various	
201XX	1/4" FNPT	0.1 – 1.0	0.4 – 4.0	A	B
205XX	1/4" FNPT	0.5 – 2.5	1.9 – 9.5	D	C
203XX	1/4" FNPT	0.8 – 6.0	3 – 27	D	C
204XX	1/4" FNPT	0.06 – 0.6	0.2 – 1.9	A	B
250XX	1/2" FNPT	1.5 – 12	6 – 45	D	C
255XX	12" FNPT	4 – 20	15 – 75	D	C
260XX	3/4" FNPT	6 – 30	22 – 110	D	C
270XX	1" FNPT	10 – 60	35 – 225	D	C

Table 1: Flow Ranges and Pipe Connections

Section 3: How do they work?

The rotor spins when liquid flows through the sensor body.

Magnets in the rotor create a voltage in an induction coil mounted in the sensor body as the rotor spins. The rotational frequency of the rotor is proportional to the linear velocity of the liquid as it passes through the sensor body. The linear velocity is proportional to the volumetric flow rate of fluid.

The rotational frequency of the rotor is measured by a simple circuit. The gain of the circuit is amplified and calibrated to provide an output of 5 VDC for the high flow limit of the flow meter. The offset of the circuit is calibrated to provide a proportional voltage output at the low flow limit of the flow meter.

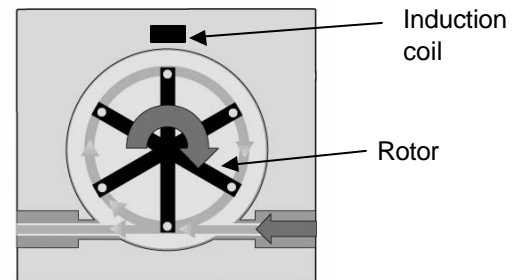

The I-versions of the 200 Series Flow Meters provide an output that is calibrated so that 20 mA represents the high flow limit and 4 mA represents the low flow limit.

Additionally, the amplified output is compared with a user-selected reference voltage to actuate the in-built relay interface.

When the measured voltage is greater than the voltage achieved at a user-selected trip point flow rate, the relay is energized. If the measured voltage is less than the voltage achieved at the user-selected trip point flow rate or if the fluid stops flowing, power to the relay is shut off, and the relay is de-energized. The de-energized state is called the relay's normal position. The change of state of the relay is interpreted by the user's equipment to control other system functions.

Section 4: Physical Installation

CAUTION!

It is generally undesirable to mount any plumbing connections directly over electronic controls or instruments.

WARNING!

If the 200 Series Flow Meter is mounted in a vertical pipeline, any leakage from the topmost connection could enter the unit and cause permanent damage to the electronics..

Pipe or tubing mounting

If rigid piping or tubing is used, the flow switch may be supported by direct connection to the pipe or tubing.

Panel mounting

To mount the sensor behind a panel, two of the faceplate securing screws will need to be replaced with longer screws to compensate for the thickness of the panel. Ensure that the screws are not so long that they will touch the bottom of the tapped hole, or rip through the back of a plastic body if over-tightened.

Evenly space up to six holes for 8-32 screws on a 2.5" circle. Using the two holes on the horizontal plane is usually sufficient to support smaller flow sensors and all plastic sensors. If you wish the rotor to be visible, cut a 1 $\frac{3}{4}$ " diameter hole with the same center.

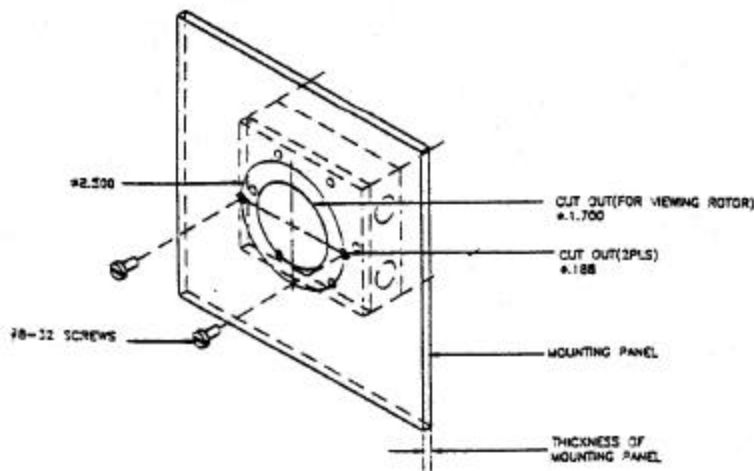

Figure 1: Panel Mounting of 200 Series Flow Meter

1. Remove screws holding the faceplate to the sensor body.
2. Place the sensor behind the panel and insert the longer screws you have selected.
3. Secure the screws in the body with a torque of ~ 10 in-lb. (Finger tight with a flat-blade screwdriver.).

Plumbing Connections

Note

Before connecting a flow switch into your fluid line, verify that the normal flow rates expected in that line are within the operating range of the sensor as shown in Table 1

Extended use above the rated maximum flow rate of the sensor will reduce its useable life.

Note

It is recommended that connections to the stainless steel flow sensor be made with stainless steel or materials of similar chemical inertness to minimize potential corrosion damage.

Note

The flow response of the sensor, and thus its output response may be dependent on the internal diameter (ID) of an incoming pipe, or the ID of a tube connection.

If the ID of your pipe or tube fitting where it connects to the inlet port is LESS than the value shown in Table 2, the flow calibration and pre-calibrated trip points may be invalid.

Model X=C,B,P or SS	Connection			Minimum ID of pipe or connection		
	Pipe Size	Inlet Port	Outlet Port	C=Celcon	P=Polypropylene	B = Brass or SS = Stainless Steel
204X	¼" NPT	A	B	Not Sensitive		
201X	¼" NPT	A	B	0.28"	0.28"	0.28
205C	¼" NPT	B	C	0.28"		
205 B or SS	¼" NPT	D	C		0.35"	0.28
203X	¼" NPT	D	C	0.28"	0.35"	0.35
250X	½" NPT	D	C	0.54"	0.54"	0.60
255X	½" NPT	D	C	0.54"	0.54"	0.60
260X	¾" NPT	D	C	Not Available		0.81
270X	1" NPT	D	C	Not Available		0.81

Table 2: Minimum ID of pipe or connection**Note**

The flow response of a 200 Series Flow Meter may be dependent on the form of a device attached to the inlet connection and other closely located up-stream devices.

Elbows, T-pieces, valves and filters located immediately up-stream from the flow sensor can introduce swirling motion to the liquid flow. The swirling motion reduces the linear velocity of the flow stream.

We recommend that a straight run of pipe of more than 10 x pipe ID be used between the flow switch and any up-stream devices to minimize these effects.

Appropriate calibration procedures must be used to provide an accurate trip point settings in systems in which elbows or T-pieces that must be attached directly to the inlet connection.

200 Series Flow Meters are typically unaffected by the form or proximity of devices on their downstream side.

Sensor Orientation

For the best results 200 Series Flow Meters should be mounted with the faceplate in the vertical plane.

Mounting the device with the flow connections uppermost can help eliminate entrained air from your system.

NPT pipe thread connections

Pipe threads seal by making metal-to-metal or plastic-to-plastic contact between male and female components. Consequently they are particularly prone to the damaging effects of galling, which occurs when two surfaces move against each other under pressure. When installing pipe threads it is essential to use a high quality lubricating and sealing material.

WARNING

Do NOT use anaerobic pipe sealants such as LOCTITE or SWAK brand sealants with these sensors. The aggressive chemical nature of these materials will cause cracking of polysulfone faceplates.

- Use Teflon tape or a PTFE-based liquid sealant to provide lubrication for the junction and a leak-tight connection at both input and output connections. Real-Tuff and Hercules are two of many suitable brands of PTFE-based sealants.
- Do not over-tighten the connection. Refer to instructions for installation of the mating fittings for information on torque requirements.
- Leak testing of all connections in your flow circuit is recommended. Pressurizing the system with air and external testing with a dilute soap solution can help identify leaking connections.

Filtering

Your circulating fluid may contain particles. While not essential to the operation of the flow sensor, it is good practice to filter your fluid. A 100-micron filter is often used to remove rust and other particles from the fluid. This can increase the lifetime of pumps and other fluid system components as well as reducing wear in the sensor.

Fluid Temperature Range

Flow sensors with plastic bodies should not be used above 75°C. Metal bodies with metal faceplates may be used with liquids to higher temperatures, however the 200 Series Flow Meters should not be used for temperatures above 110°C.

For higher temperature situations, contact **Technical Support** at **650 964 4163** or Tech@proteusind.com for assistance in selecting the flow sensor best suited to your application.

Section 5: Electrical Connections

Note

Only personnel familiar with the electrical circuit and control functions of the system in which the sensors are to be included should perform installation of this product.

24V-DC and 12 V-DC versions of the 200 Series Flow Meter are fitted with a seven-core cable for connection to the user's control system. Color codes and wiring connections are shown in Tables 4.

24V-DC and 12V-DC wiring Diagrams

Color	+12 VDC Input 0-5V analog output	+24 VDC Input 0-5V analog out	+24 VDC Input 4-20ma output
Red	+12 VDC	+24 VDC	+24 VDC
Black	Ground		
Brown	0-5 VDC Out		0 to 20 mA out
White	Ground		
Orange	+5 VDC out*		
Green	Relay-Normally Open		
Blue	Relay Common		

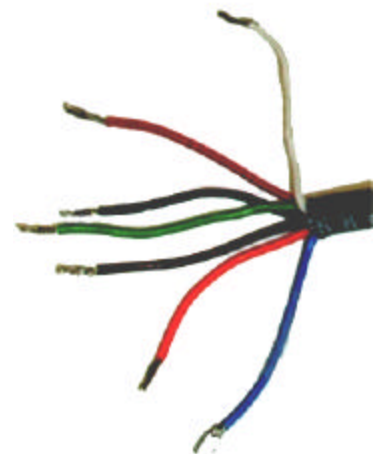

Section 6: Setting the Trip Point

- The trip point should be at least 10% below the normal operating flow rate.
- Avoid selecting a flow switch where your normal flow will be in the bottom 20% of the range, forcing you to set the trip point close to both the normal flow rate and the bottom of the range.

The trip point may be set prior to shipment at the factory if a Model 970 Preset Charge is ordered and a trip point specified. The trip point is set to be accurate on falling flow of water unless you specify rising flow.

User adjustment

The trip point is adjusted with a 20-turn potentiometer accessible from the in the back of the electronics enclosure.

1. Remove the replaceable yellow label that covers the potentiometer hole.
2. Insert inserting a small screwdriver through the hole in the back of the electronics case.

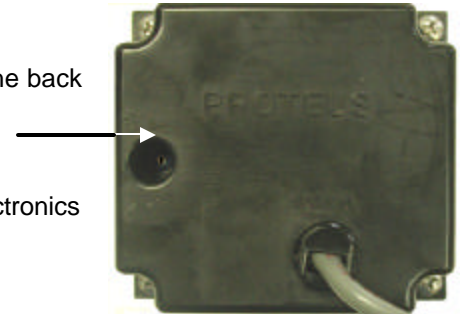

Turning the potentiometer clockwise will lower the trip point.

Turning the potentiometer counterclockwise will raise the trip point.

3. To set the trip point, install the flow switch in your actual circuit or on to your calibration bench.

If you are using a separate calibration bench, make sure you use the same style of inlet fitting as you will use on your actual installation!

4. Adjust the actual fluid flow rate to the minimum acceptable flow rate.

Ensure that the flow rate is steady and that all air has been purged from the flow line.

5. Connect an ohmmeter or continuity meter between the BLUE (common) and GREEN (normally open NO) wires in the output cable.
6. Adjust the potentiometer until the meter indicates the relay has tripped.

For the NO connection, the contacts will open, indicated by the measured resistance changing from 0 ohms to infinite resistance.

7. ***There is a small time delay between when the trip point is crossed and when the relay trips. The adjustment should be made slowly to avoid overshooting.***



Note:



The actual trip point flow is different for rising and falling flows. For applications in which an exact setting is required, be sure to test the trip point by reducing flow through the trip point or increasing flow to rise through the trip point as required by your particular application.

Section 7: Maintenance

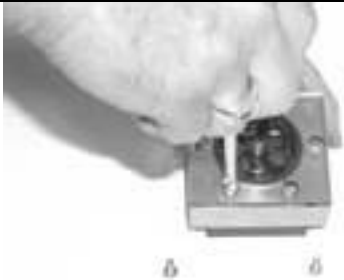
Maintenance of the sensor is normally limited to cleaning the chamber in which the rotor spins and annual recalibration.

The frequency of cleaning will vary with the type of fluid being run and the cleanliness of that fluid. In most cases, annual cleaning immediately prior to recalibration is sufficient.

Cleaning the 200 Series Flow Meter	
<p>1. Turn OFF the liquid flow in your flow circuit and remove the flow sensor or transducer sensor from your system. Place the unit on a clean surface.</p>	
<p>2. Remove the 6 screws securing the faceplate.</p>	
<p>3. Remove the faceplate from the flow meter.</p>	
<p>4. Remove the rotor and stainless steel shaft from the flow cavity.</p> <p>Remove the O-ring from the faceplate</p>	

Cleaning the 200 Series Flow Meter	
<p>5. Using a soft cloth dampened with water, alcohol or a light detergent solution, clean debris and dirt from the rotor, the stainless steel shaft, the inside surfaces of faceplate and the surfaces of the flow cavity</p>	
<p>6. Inspect the bearing surface of the rotor. If the bearing surface is worn or not round, replace the rotor.</p> <p>Inspect the stainless steel shaft. If the shaft shows signs of scoring or other wear, replace the shaft or the whole faceplate assembly.</p>	
<p>7. Inspect the O-ring to ensure that it is not brittle, cracked or otherwise damaged.</p> <p>If necessary replace with a #132 O-ring of a material compatible with the liquid being passed through the flow meter.</p> <p>Position the O-ring on the inner rim of the faceplate.</p>	
<p>8. Place the rotor in the flow cavity.</p> <p>Position the shaft (or the faceplate) to locate the shaft in the rotor.</p>	
<p>9. Position the faceplate so that the holes in the faceplate are aligned with the screw holes in the front of the flow sensor body.</p> <p>Replace the 6 securing screws.</p> <p>Tighten the screws to a torque of 10 in-lbs (hand tighten with a normal screwdriver).</p>	
<p>11. Install the flow switch in your system. Turn on liquid flow and check for leaks at the faceplate and connecting ports. Tighten all connections as required to eliminate leaks.</p>	

Section 8: Calibration

Note

200 Series Flow Meters are calibrated at Proteus with water at temperatures ranging from 22 to 28°C.

***Changes in fluid type can alter the calibrated response of the sensor.
Large changes in liquid temperature can alter the calibrated response of the sensor.***

Please contact Proteus Technical Support if a specialized calibration is needed.

Note

As described in the Plumbing Connections section on page 3, the response of the 200 Series Flow Meter may be affected by the way in which the sensor is connected to your system.

The 200 Series Flow Meter has been calibrated during manufacture to provide an output of 5.0 VDC or 20 mA for the high flow range limit of the flow meter, with straight pipe connections.

Customized calibration procedures can be performed to change the flow rate corresponding to 5.0 VDC or 20 mA, for fluids other than water and with connections with internal diameters less than those used in the flow sensors. (See Table 2, page 6).

Recalibration

The calibration of the 200 Series Flow Meter should be checked at 12-month intervals, and recalibrated as required. Re-calibration may be accomplished in either of two ways:

Calibration by Proteus

To obtain a price quotation and a Return Material Authorization number for recalibration of your flow meter, contact Sales@proteusind.com or call (650) 964 4163.

When received at Proteus your flow meter will:

1. Have its output measured and recorded in the as-received state.
2. The rotor, stainless steel shaft and sealing O-ring will be replaced.
3. The flow cavity will be cleaned and the device reassembled..
4. The unit will be recalibrated to its original specification against reference standards whose calibrations are statistically controlled against NIST-traceable standards.
5. A new calibration certificate will be issued.
6. A new calibration label will be attached to the flow meter.

Direct calibration against NIST-traceable standards is optionally available.

Calibration by another laboratory.

The calibrating laboratory will issue certificates and labels identifying the calibration status of your metering flow switch.

Please advise your selected calibration laboratory to contact Proteus for calibration instructions.

Section 9: General

Trademarks

Celcon, Nylon and Kynar are registered trademarks of Celanese Plastics, DuPont and Elf-Autochem. Real-Tuff, Hercules, Loctite and SWAK are trademarks of their respective holders.

Section 10: Reference Documents

Circuit Diagrams

WARNING NOTE

These diagrams are provided as reference information. We recommend that you do NOT attempt to repair a flow meter circuit board, as generally the equipment or process being protected by the flow switch has a much higher value than a replacement set of electronics or a replacement flow meter!

Replacement mechanical and electrical subsystems for 200 Series Flow Meters are accessible from our website at www.proteusind.com

200106D-sch-1 - Wed Sep 25 15:00:15 2002

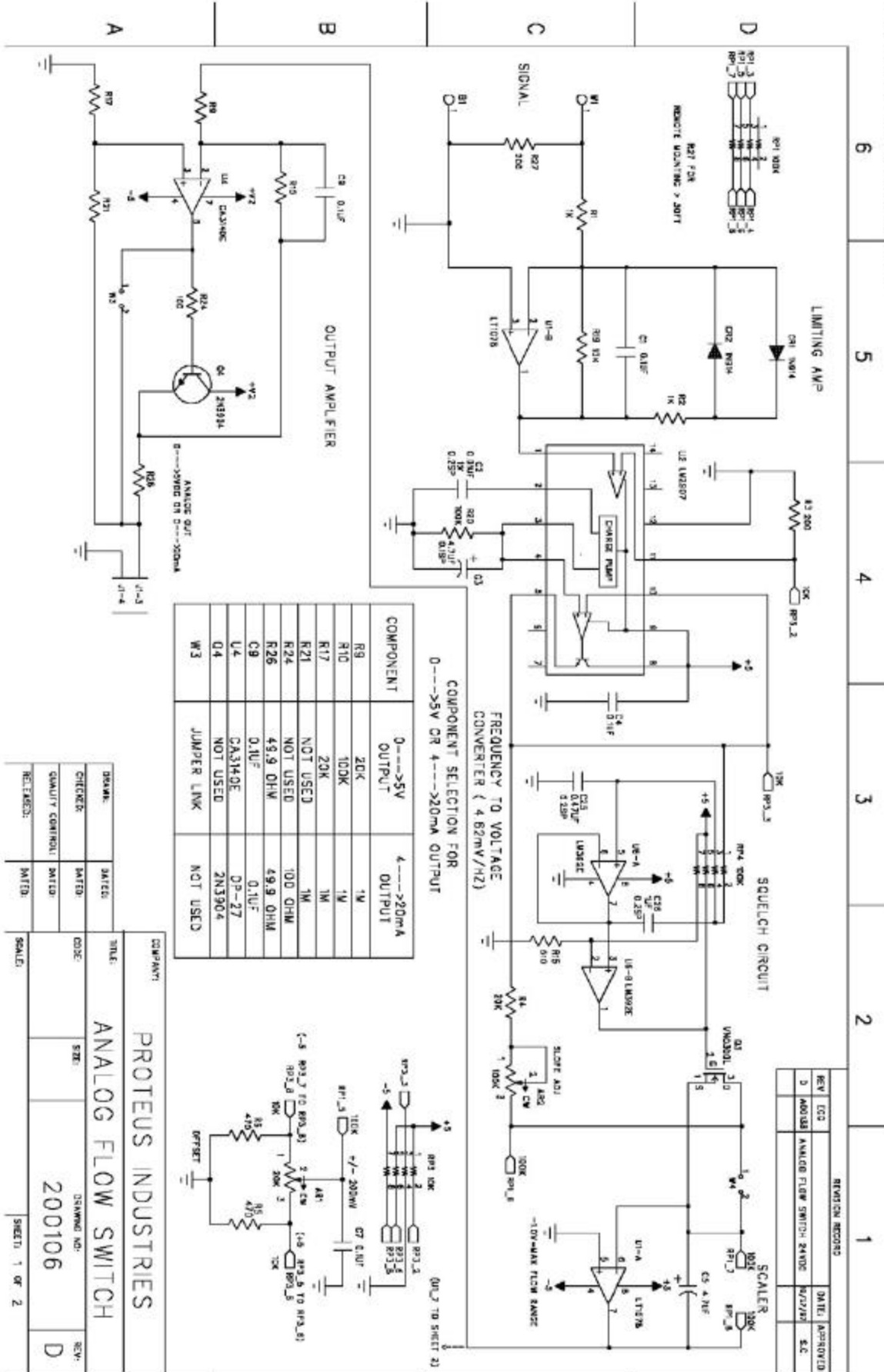

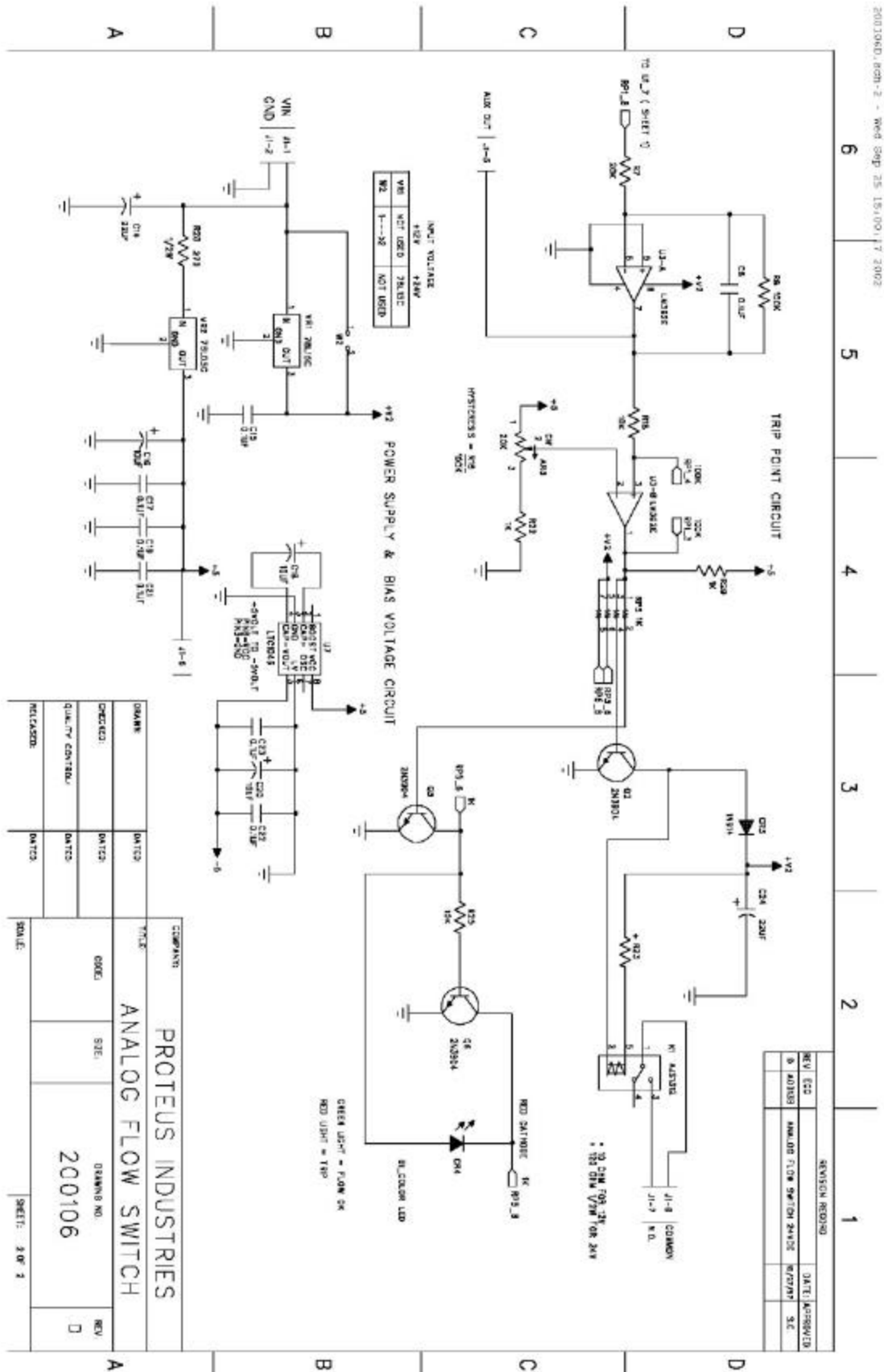

200106D, Rev-2 - Rev Sep. 25, 19:00, 17, 2002